

SC-310/SC-740 Chambers



StormTech®

Detention • Retention • Recharge

Subsurface Stormwater ManagementSM

Design Manual

StormTech® Chamber Systems
for Stormwater Management

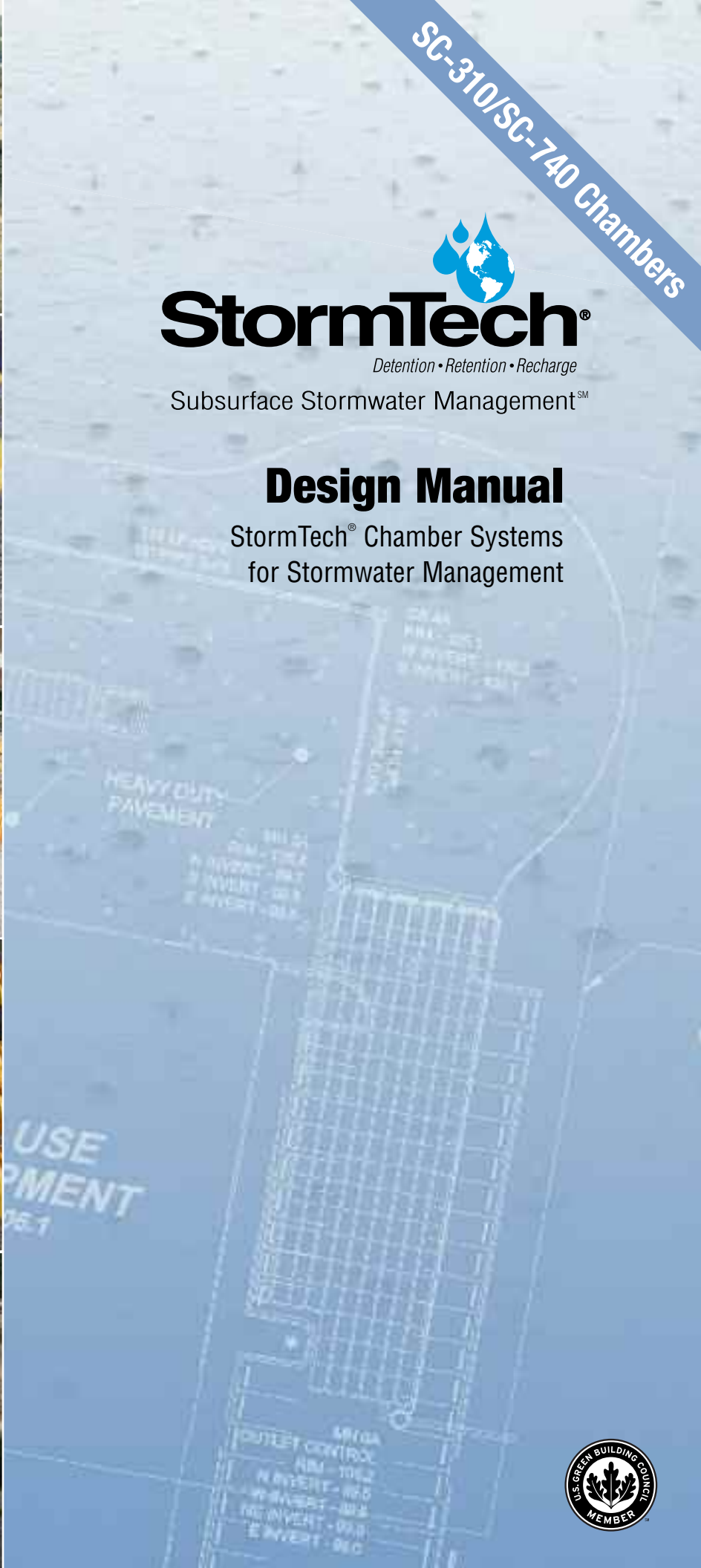
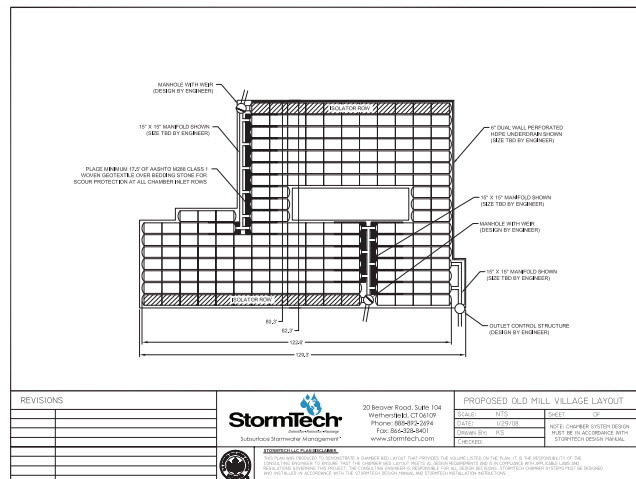


Table of Contents



1.0 Introduction	2
2.0 Product Information	3
3.0 Structural Capabilities	6
4.0 Foundation for Chambers	8
5.0 Required Materials and Row Separation.....	9
6.0 Inletting the Chambers	10
7.0 Outlets for Chambers	13
8.0 Cumulative Storage Volumes.....	14
9.0 Other Considerations.....	15
10.0 System Sizing	16
11.0 Materials Worksheet	17
12.0 Detail Drawings	18
13.0 Inspection and Maintenance	21
14.0 General Notes	23
15.0 StormTech Product Specifications.....	24
16.0 Chamber Specifications for Contract Documents.....	25

StormTech Technical Services Department assists design professionals in specifying StormTech stormwater systems. This assistance includes the layout of chambers to meet the engineer's volume requirements and the connections to and from the chambers. The Technical Department can also assist converting and cost engineering projects currently specified with ponds, pipe, concrete and other manufactured stormwater detention/retention products. Please note that it is the responsibility of the design engineer to ensure that the chamber bed layout meets all design requirements and is in compliance with applicable laws and regulations governing this project.



This manual is exclusively intended to assist engineers in the design of subsurface stormwater systems using StormTech chambers.

1.0 Introduction

1.1 INTRODUCTION

StormTech stormwater management systems allow stormwater professionals to create more profitable, environmentally sound developments. Compared with other subsurface systems, StormTech systems offer lower overall installed cost, superior design flexibility and enhanced performance. Applications include commercial, residential, agricultural and highway drainage.

StormTech has invested over \$7.5 million and four years in the development of StormTech chambers. These innovative products exceed the rigorous requirements of the stormwater industry.

1.2 THE GOLD STANDARD IN STORMWATER MANAGEMENT

The advanced designs of StormTech chambers were created by implementing an aggressive research, development, design and manufacturing protocol. StormTech chamber products establish the new gold standard in stormwater management through:

- Collaborations with experts in the field of buried plastic structures and polyolefin materials
- The development and utilization of new testing methods and proprietary test methods
- The use of thermoformed prototypes to verify engineering models, perform in-ground testing and install observation sites
- The investment in custom-designed, injection molding equipment
- The utilization of polypropylene as a manufacturing material
- The design of molded-in features not possible with traditional thermoformed chambers

Section 3.0 of this design manual, *Structural Capabilities*, provides a detailed description of the research, development and design process.

Many of StormTech's unique chamber features can benefit a site developer, stormwater system designer, and installer. Where applicable, StormTech Product Specifications are referenced throughout this design manual. If StormTech's unique product benefits are important to a stormwater system design, consider including the applicable StormTech Product Specifications on the site plans. This can prevent substitutions with inferior products. Refer to Section 15.0, *StormTech Product Specifications*.

1.3 PRODUCT QUALITY AND DESIGN TO INTERNATIONAL STANDARDS

StormTech chambers are produced to the requirements of the American Society of Testing Materials (ASTM) International specification F 2418 "Standard Specification for

Polypropylene (PP) Corrugated Wall Stormwater Collection Chambers." StormTech played an integral part in the development of this international standard by completing a cutting-edge materials research program that established the necessary 50-year creep modulus value for injection grade polypropylene for long term structural design.

The ASTM F 2418 standard is linked to the American Association of State Highway Transportation Officials (AASHTO) LRFD Bridge Design Specifications Section 12.12 design standard. ASTM F 2418 requires that the safety factors included in the AASHTO guidance are achieved as a prerequisite to meeting ASTM F 2418. The two standards provide both assurance of product quality and safe structural design. Refer to Section 3.0 for more on structural design.

For non-proprietary specifications for public bids that ensure high product quality and safe design, consider including the specification in Section 16.0 Chamber Specifications for Contract Documents.

1.4 TECHNICAL SUPPORT FOR PLAN REVIEWS

StormTech's in-house technical support staff is available to review proposed plans that incorporate StormTech chamber systems. They are also available to assist with plan conversions from existing products to StormTech. Not all plan sheets are necessary for StormTech's review. Required sheets include plan view sheet(s) with design contours, cross sections of the stormwater system including catch basins and drainage details.

When specifying StormTech chambers it is recommended that the following items are included in project plans: StormTech chamber system General Notes, applicable StormTech chamber illustrations and StormTech chamber system Product Specifications. These items are available in various formats and can be obtained by contacting StormTech at **1-860-529-8188** or may be downloaded at **www.stormtech.com**.

StormTech's plan review is limited to the sole purpose of determining whether plans meet StormTech chamber systems' minimum requirements. **It is the ultimate responsibility of the design engineer to assure that the stormwater system's design is in full compliance with all applicable laws and regulations.** StormTech products must be designed and installed in accordance with StormTech's minimum requirements.

SEND PLANS TO:

StormTech LLC, Plan Review, 20 Beaver Road, Suite 104, Wethersfield, CT 06109 E-mail: techinfo@stormtech.com. File size should not exceed 10 MB.

2.0 Product Information



2.1 PRODUCT APPLICATIONS

StormTech chamber systems may function as stormwater detention, retention, first-flush storage, or some combination of these. The StormTech chambers can be used for commercial, municipal, industrial, recreational, and residential applications especially for installations under parking lots and commercial roadways.

One of the key advantages of the StormTech chamber system is its design flexibility. Chambers may be configured into beds or trenches of various sizes or shapes. They can be centralized or decentralized, and fit on nearly all sites. Chamber lengths enhance the ability to develop on both existing and pre-developed projects. The systems can be designed easily and efficiently around utilities, natural or man-made structures and any other limiting boundaries.

2.2 CHAMBERS FOR STORMWATER DETENTION

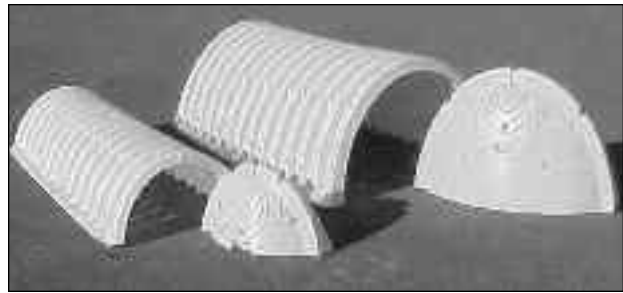
Chamber systems have been used effectively for stormwater detention for over 15 years. A detention system temporarily holds water while it is released at a defined rate through an outlet. While some infiltration may occur in a detention system, it is often considered an environmental benefit and a storage safety factor. Over 70% of StormTech's installations are non-watertight detention systems. There are only a few uncommon situations where a detention system might need to limit infiltration: the subgrade soil's bearing capacity is significantly affected by saturation such as with expansive clays or karst soils, and; in sensitive aquifer areas where the depth to groundwater does not meet local guidelines. Adequate pretreatment could eliminate concerns for the latter case. A thermoplastic liner may be considered for both situations to limit infiltration. Contact StormTech's Technical Service Department for more information on using StormTech chambers in your application.

2.3 STONE POROSITY ASSUMPTION

A StormTech chamber system requires the application of clean, crushed, angular stone below, between and above the chambers. This stone serves as a structural component while allowing conveyance and storage of stormwater. Storage volume examples throughout this Design Manual are calculated with an assumption that the stone has an industry standard porosity of 40%. Actual stone porosity may vary. Contact StormTech for information on calculating stormwater volumes with varying stone porosity assumptions.

2.4 CHAMBER SELECTION

StormTech currently offers two chamber sizes for stormwater management. These chambers have been designed to optimize and balance storage volumes with respect to depth and area constraints.



The SC-310 and SC-740 chambers and end plates.



StormTech systems can be integrated into retrofit and new construction projects.



StormTech chambers may be configured into beds or trenches.

Primary considerations when selecting between the SC-740™ and SC-310™ chambers are the depth to groundwater, available area for subsurface storage and outfall restrictions.

The StormTech SC-740 chamber shown in **Figure 1** on page 4 optimizes storage volumes in relatively small footprints. By providing 2.2 ft³/ft² (0.67 m³/m²) [minimum] of storage, the SC-740 chambers can minimize excavation, backfill and associated costs.

The StormTech SC-310 chamber shown in **Figure 2** on page 4 is ideal for systems requiring low-rise and wide-span solutions. This low profile chamber allows the storage of large volumes, 1.3 ft³/ft² (0.40 m³/m²) [minimum], at minimum depths. *Product Specifications: 2.2 and 2.5*

2.0 Product Information

Figure 1 – StormTech SC-740 Chamber (not to scale)

Nominal Chamber Specifications

Size (W x H x Installed L)	51.0" (1295 mm) x 30.0" (762 mm) x 85.4" (2169 mm)
Chamber Storage	45.9 ft ³ (1.30 m ³)
Min. Installed Storage*	74.9 ft ³ (2.12 m ³)
Weight	74 lbs (33.6 kg)

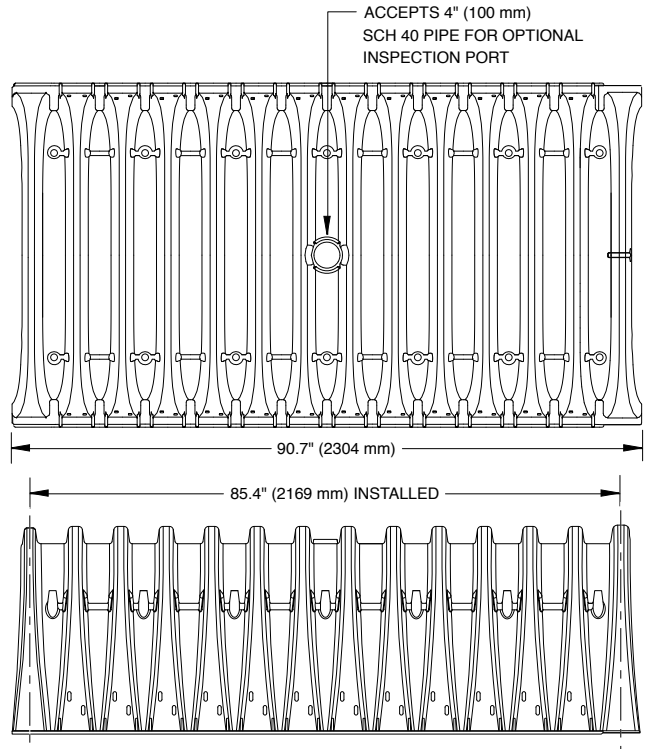
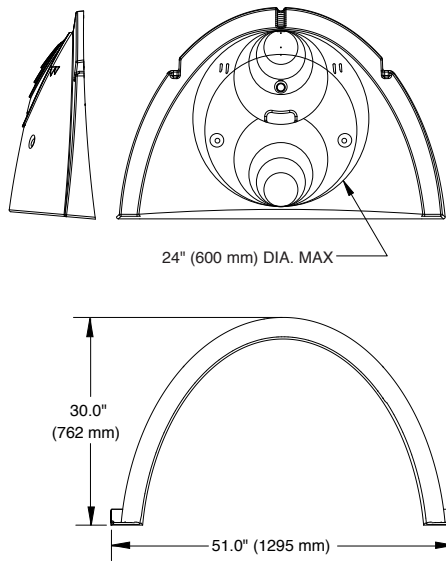
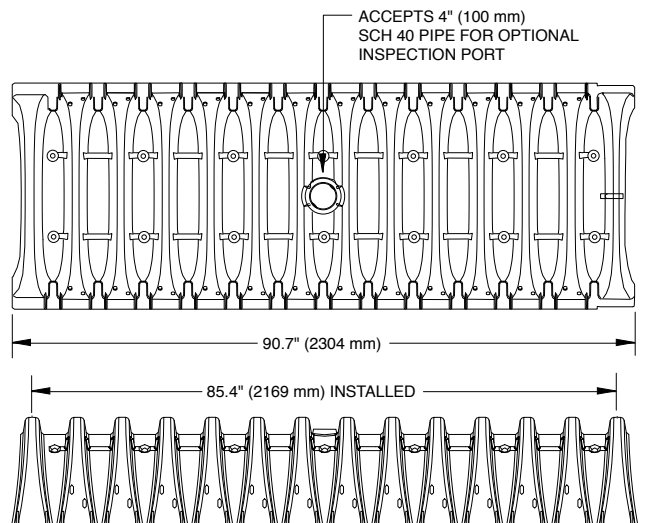
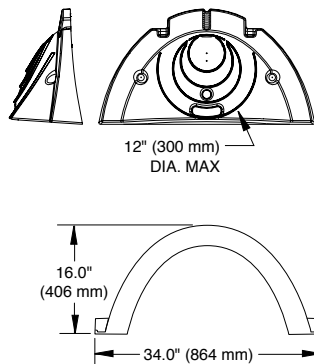


Figure 2 – StormTech SC-310 Chamber (not to scale)

Nominal Chamber Specifications

Size (W x H x Installed L)	34.0" (864 mm) x 16.0" (406 mm) x 85.4" (2169 mm)
Chamber Storage	14.7 ft ³ (0.42 m ³)
Min. Installed Storage*	31.0 ft ³ (0.88 m ³)
Weight	37 lbs (16.8 kg)



*This assumes a minimum of 6" (152 mm) of stone below, above and between chamber rows and 40% stone porosity.

2.5 STORMTECH CHAMBERS

StormTech chamber systems have unique features to improve site optimization and reduce product waste. The SC-740 and SC-310 chambers can be cut at the job site in approximately 6.5" (165 mm) increments to shorten a chamber's length. Designing and constructing chamber rows around site obstacles is easily accomplished by including specific cutting instructions or a well placed "cut to fit" note on the design plans. The last chamber of a row can be cut in any of its corrugation's valleys. An end cap placed into the trimmed corrugation's crest completes the row. The trimmed-off piece of a StormTech chamber may then be used to start the next row. See **Figure 3**.

To assist the contractor, StormTech chambers are molded with simple assembly instructions and arrows that indicate the direction in which to build rows. Rows are formed by overlapping the next chamber's "Start End" corrugation with the previously laid chamber's end corrugation. Two people can safely and efficiently form rows of chambers without complicated connectors, special tools or heavy equipment.

Product Specifications: 2.2, 2.4, 2.9 and 3.2

2.6 STORMTECH END CAPS

The StormTech end cap has features which make the chamber system simple to design, easy to build and more versatile than other products. StormTech end caps can be easily secured within any corrugation's crest. A molded-in handle makes attaching the end cap a one-person operation. Tools or fasteners are not required.

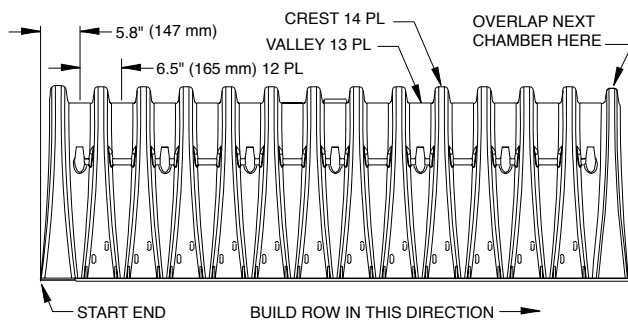
StormTech end caps are required at each end of a chamber row to prevent stone intrusion (two per row). The SC-740 end cap will accept up to a 24" (600 mm)



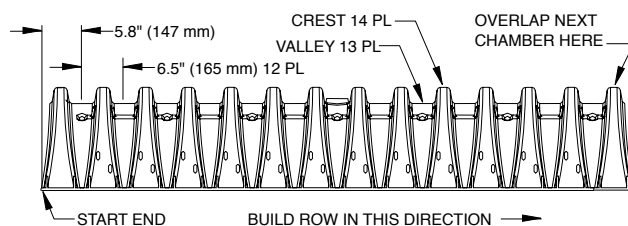
HDPE inlet pipe. The SC-310 end cap will accept up to a 12" (300 mm) HDPE inlet pipe. To aid contractors, inlet pipe cutting guides and a blade-starting slot are molded into the end caps. See **Figure 4**.

Product Specifications: 3.1, 3.2, 3.3 and 3.4

Figure 3 – Distance Between Corrugations (not to scale)

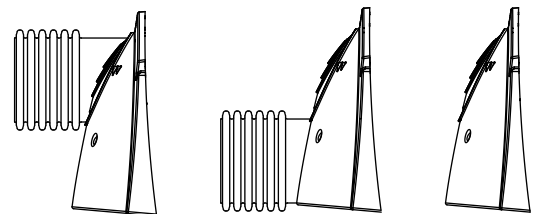


SC-740 chamber



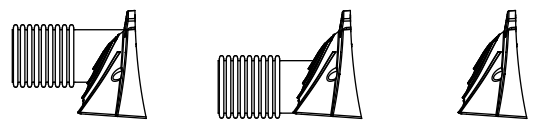
SC-310 chamber

Figure 4 – Chamber End Caps (not to scale)



SC 740 CHAMBER FABRICATED END CAP (TOP AND BOTTOM FEED)
PIPES SIZES RANGE FROM 6" (152 mm) TO 24" (600 mm)
(INVERTS VARY WITH PIPE SIZE)

SC-740 end cap



SC 310 CHAMBER FABRICATED END CAP (TOP AND BOTTOM FEED)
PIPES SIZES RANGE FROM 6" (152 mm) TO 12" (600 mm)
(INVERTS VARY WITH PIPE SIZE)

SC-310 end cap

3.0 Structural Capabilities



3.1 STRUCTURAL DESIGN APPROACH

When installed per StormTech's minimum requirements, StormTech products are designed to exceed American Association of State Highway and Transportation Officials (AASHTO) LRFD recommended design factors for Earth loads and Vehicular live loads. AASHTO Vehicular live loads (previously HS-20) consist of two heavy axle configurations, that of a single 32 (142 kN) kip axle and that of tandem 25 (111 kN) kip axles. Factors for impact and multiple presences of vehicles ensure a conservative design where structural adequacy is assumed for a wide range of street legal vehicle weights and axle configurations.

Computer models of the chambers under shallow and deep conditions were developed. Utilizing design forces from computer models, chamber sections were evaluated using AASHTO procedures that consider thrust and moment, and check for local buckling capacity. The procedures also considered the time-dependent strength and stiffness properties of polypropylene. These procedures were developed in a research study conducted by the National Cooperative Highway Research Program (NCHRP) for AASHTO, and published as NCHRP Report 438 Recommended LRFD Specifications for Plastic Pipe and Culverts. *Product Specifications: 2.12.*

StormTech does not recommend installing StormTech products underneath buildings or parking garages. When specifying the StormTech products in close proximity to buildings, it is important to ensure that the StormTech products are not receiving any loads from these structures that may jeopardize the long term performance of the chambers.



3.2 FULL SCALE TESTING

After developing the StormTech chamber designs, the chambers were subjected to rigorous full-scale testing. The test programs verified the predicted safety factors of the designs by subjecting the chambers to more severe load conditions than anticipated during service life. Capacity under live loads and deep fill was investigated by conducting tests with a range of cover depths. Monitoring of long term deep fill installations has been done to validate the long term performance of the StormTech products.

3.3 INDEPENDENT EXPERT ANALYSIS

StormTech worked closely with the consulting firm Simpson Gumpertz & Heger Inc. (SGH) to develop and evaluate the SC-740 and SC-310 chamber designs. SGH has world-renowned expertise in the design of buried drainage structures. The firm was the principal investigator for the NCHRP research program that developed the structural analysis and design methods recently adopted by AASHTO for thermoplastic culverts. SGH conducted design calculations and computer simulations of chamber performance under various installation and live load conditions. They worked with StormTech to design the full-scale test programs to verify the structural capacity of the chambers. SGH also observed all full-scale tests and inspected the chambers after completion of the tests. SGH continues to be StormTech's structural consultant.

3.0 Structural Capabilities



3.4 INJECTION MOLDING

To comply with both the structural requirements of AASHTO's LRFD design and analysis methods and product requirements of ASTM F2418 "Standard Specification for Polypropylene Corrugated Wall Stormwater Collection Chambers," StormTech utilizes proprietary injection molding equipment to manufacture the SC-740 and SC-310 chambers and end caps.

In addition to meeting structural goals, injection molding allows StormTech to design added features and advantages into StormTech's parts including:

- Precise control of wall thickness throughout parts
- Precise fit of joints and end caps
- Molded-in inspection port fitting
- Molded-in handles on end caps
- Molded-in pipe guides with blade starter slots
- Repeatability for Quality Control (See Section 3.6)

Product Specifications: 2.1, 3.1 and 3.3

3.5 POLYPROPYLENE RESIN

StormTech chambers are injection molded from polypropylene. Polypropylene chambers are inherently resistant to chemicals typically found in stormwater run-off. StormTech chambers maintain a greater portion of their structural stiffness through higher installation and service temperatures.

StormTech polypropylene is a virgin material specially designed to achieve a high 50-year creep modulus that is necessary to provide a sound long-term structural design. Since the modulus remains high well beyond the 50-year value, StormTech chambers can exhibit a service life in excess of 50 years.



3.6 QUALITY CONTROL

StormTech SC-740 and SC-310 stormwater chambers are manufactured under tight quality control programs. Materials are routinely tested in an environmentally controlled lab that is verified every six months via the external ASTM Proficiency Testing Program. The chamber material properties are measured and controlled with procedures following ISO 9001:2000 requirements.

Statistical Process Control (SPC) techniques are applied during manufacturing. Established upper and lower control limits are maintained on key manufacturing parameters to maintain consistent product.

Product Specifications: 2.13 and 3.6

4.0 Foundation for Chambers

4.1 FOUNDATION REQUIREMENTS

StormTech SC-740 and SC-310 chamber systems and embedment stone may be installed in various native soil types. The sub-grade bearing capacity and chamber cover height determine the required depth of clean, crushed, angular stone for the chamber foundation. The chamber foundation is the clean, crushed, angular stone placed between the subgrade soils and the feet of the chamber.

As cover height increases (top of chamber to top of finished grade) the chambers foundation requirements increase. Foundation strength is the product of the sub-grade soils bearing capacity and the depth of clean, crushed, angular stone below the chambers feet. **Table 1** specifies the required minimum foundation depth for varying cover heights and subgrade bearing capacities.

The design engineer is responsible for assessing the bearing capacity of the sub-grade soil. Sub-grade soil conditions should be assessed with consideration of the range of soil moisture contents expected under a stormwater system.

4.2 WEAKER SOILS

For sub-grade soils with allowable bearing capacity less than 2000 pounds per square foot [(2.0 ksf) (96 kPa)], a geotechnical engineer should evaluate the specific conditions. These soils are often highly variable, may

contain organic materials and could be more sensitive to moisture. A geotechnical engineer's recommendations may include increasing the stone foundation to greater than 18 inches (457 mm), improving the bearing capacity of the sub-grade soils through compaction, replacement, or other remedial measures including the use of geogrids. The use of a thermoplastic liner may also be considered for systems installed in subgrade soils that are highly affected by moisture. The project engineer is responsible for ensuring overall site settlement is within acceptable limits. A geotechnical engineer should always review installation of StormTech chambers on organic soils.

4.3 CHAMBER SPACING OPTION

StormTech always requires a minimum of 6" (152 mm) clear spacing between the feet of chambers rows. However, increasing the spacing between chamber rows may allow the application of StormTech chambers with either less foundation stone or with weaker subgrade soils. This may be a good option where a vertical restriction on site prevents the use of a deeper foundation. Contact StormTech's Technical Service Department for more information on this option. In all cases, StormTech recommends consulting a geotechnical engineer for subgrade soils with a bearing capacity less than 2.0 ksf (96 kPa).

Table 1 – Minimum Required Foundation Depth in Inches (mm)

Cover Ht. ft. (m)	Minimum Required Bearing Resistance for Service Loads ksf (kPa)																					
	4.1 (196)	4.0 (192)	3.9 (187)	3.8 (182)	3.7 (177)	3.6 (172)	3.5 (168)	3.4 (163)	3.3 (158)	3.2 (153)	3.1 (148)	3.0 (144)	2.9 (139)	2.8 (134)	2.7 (129)	2.6 (124)	2.5 (120)	2.4 (115)	2.3 (110)	2.2 (105)	2.1 (101)	2.0 (96)
1.5 (0.46)	6 (152)	6 (152)	6 (152)	6 (152)	6 (152)	6 (152)	6 (152)	6 (152)	6 (152)	6 (152)	6 (152)	6 (152)	9 (229)	9 (229)	9 (229)	9 (229)	9 (229)	12 (305)	12 (305)	12 (305)	15 (381)	15 (381)
2 (0.61)	6 (152)	6 (152)	6 (152)	6 (152)	6 (152)	6 (152)	6 (152)	6 (152)	6 (152)	6 (152)	6 (152)	6 (152)	9 (229)	9 (229)	9 (229)	9 (229)	9 (229)	12 (305)	12 (305)	12 (305)	15 (381)	15 (381)
2.5 (0.76)	6 (152)	6 (152)	6 (152)	6 (152)	6 (152)	6 (152)	6 (152)	6 (152)	6 (152)	6 (152)	9 (229)	9 (229)	9 (229)	9 (229)	9 (229)	12 (305)	12 (305)	12 (305)	15 (381)	15 (381)	15 (381)	18 (457)
3 (0.91)	6 (152)	6 (152)	6 (152)	6 (152)	6 (152)	6 (152)	6 (152)	6 (152)	6 (152)	9 (229)	9 (229)	9 (229)	9 (229)	9 (229)	12 (305)	12 (305)	12 (305)	15 (381)	15 (381)	15 (381)	18 (457)	18 (457)
3.5 (1.07)	6 (152)	6 (152)	6 (152)	6 (152)	6 (152)	6 (152)	6 (152)	6 (152)	9 (229)	9 (229)	9 (229)	9 (229)	9 (229)	12 (305)	12 (305)	12 (305)	12 (305)	15 (381)	15 (381)	18 (457)	18 (457)	21 (533)
4 (1.22)	6 (152)	6 (152)	6 (152)	6 (152)	6 (152)	6 (152)	6 (152)	6 (152)	9 (229)	9 (229)	9 (229)	9 (229)	9 (229)	12 (305)	12 (305)	12 (305)	12 (305)	15 (381)	15 (381)	18 (457)	18 (457)	21 (533)
4.5 (1.37)	6 (152)	6 (152)	6 (152)	6 (152)	6 (152)	6 (152)	6 (152)	6 (152)	9 (229)	9 (229)	9 (229)	9 (229)	9 (229)	12 (305)	12 (305)	12 (305)	12 (305)	15 (381)	15 (381)	18 (457)	18 (457)	21 (533)
5 (1.52)	6 (152)	6 (152)	6 (152)	6 (152)	6 (152)	6 (152)	6 (152)	6 (152)	9 (229)	9 (229)	9 (229)	9 (229)	9 (229)	12 (305)	12 (305)	12 (305)	15 (381)	15 (381)	15 (381)	18 (457)	18 (457)	21 (533)
5.5 (1.68)	6 (152)	6 (152)	6 (152)	6 (152)	6 (152)	6 (152)	6 (152)	9 (229)	9 (229)	9 (229)	9 (229)	9 (229)	12 (305)	12 (305)	12 (305)	12 (305)	15 (381)	15 (381)	15 (381)	18 (457)	18 (457)	21 (533)
6 (1.83)	6 (152)	6 (152)	6 (152)	6 (152)	6 (152)	6 (152)	9 (229)	9 (229)	9 (229)	9 (229)	9 (229)	9 (229)	12 (305)	12 (305)	12 (305)	15 (381)	15 (381)	15 (381)	18 (457)	18 (457)	21 (533)	21 (533)
6.5 (1.98)	6 (152)	6 (152)	6 (152)	6 (152)	6 (152)	9 (229)	9 (229)	9 (229)	9 (229)	9 (229)	9 (229)	9 (229)	12 (305)	12 (305)	12 (305)	15 (381)	15 (381)	15 (381)	18 (457)	18 (457)	21 (533)	24 (610)
7 (2.13)	6 (152)	6 (152)	6 (152)	6 (152)	9 (229)	9 (229)	9 (229)	9 (229)	9 (229)	9 (229)	12 (305)	12 (305)	12 (305)	12 (305)	15 (381)	15 (381)	15 (381)	18 (457)	18 (457)	21 (533)	21 (533)	24 (610)
7.5 (2.29)	6 (152)	6 (152)	6 (152)	9 (229)	9 (229)	9 (229)	9 (229)	9 (229)	12 (305)	12 (305)	12 (305)	12 (305)	12 (305)	15 (381)	15 (381)	15 (381)	18 (457)	18 (457)	21 (533)	21 (533)	24 (610)	27 (686)
8 (2.44)	6 (152)	9 (229)	9 (229)	9 (229)	9 (229)	9 (229)	9 (229)	12 (305)	12 (305)	12 (305)	12 (305)	12 (305)	15 (381)	15 (381)	15 (381)	18 (457)	18 (457)	21 (533)	21 (533)	24 (610)	24 (610)	27 (686)

NOTE: The design engineer is solely responsible for assessing the bearing resistance (allowable bearing capacity) of the sub-grade soils and determining the depth of foundation stone. Subgrade bearing resistance should be assessed with consideration for the range of soil moisture conditions expected under a stormwater system.

5.0 Required Materials/Row Separation



5.1 CHAMBER ROW SEPARATION

StormTech SC-740 and SC-310 chambers must be specified with a minimum 6" (152 mm) space between the feet of adjacent parallel chamber rows. Increasing the space between rows is acceptable. This will increase the storage volume due to additional stone voids.

5.2 STONE SURROUNDING CHAMBERS

Refer to **Table 2** for acceptable stone materials. StormTech requires clean, crushed, angular stone below, between and 6" (152 mm) above chambers as shown in **Figure 5**. Acceptable gradations are listed in **Table 2**. Subrounded and rounded stone are not acceptable.

5.3 GEOTEXTILE SEPARATION REQUIREMENT

A non-woven geotextile that meets AASHTO M288 Class 2 Separation requirements must be applied as a separation layer to prevent soil intrusion into the clean, crushed,

angular stone as shown in **Figure 5**. The geotextile is required between the clean, crushed, angular stone and the subgrade soils, the excavation's sidewalls and the fill materials. The geotextile should completely envelope the clean, crushed, angular stone. Overlap adjacent geotextile rolls per AASHTO M288 separation guidelines. See **Table 4** for a list of acceptable geotextiles.

5.4 FILL ABOVE CHAMBERS

Refer to **Table 2** and **Figure 5** for acceptable fill material above the 6" (152 mm) of clean, crushed, angular stone. StormTech requires a minimum of 18" (457 mm) and a maximum of 96" (2438 mm) of fill material [including the 6" (152 mm) of stone above chambers]. StormTech requires a minimum of 24" (610 mm) of fill in non-paved installations where rutting from vehicles may occur. **Table 2** provides details on soil class and compaction requirements for suitable fill materials.

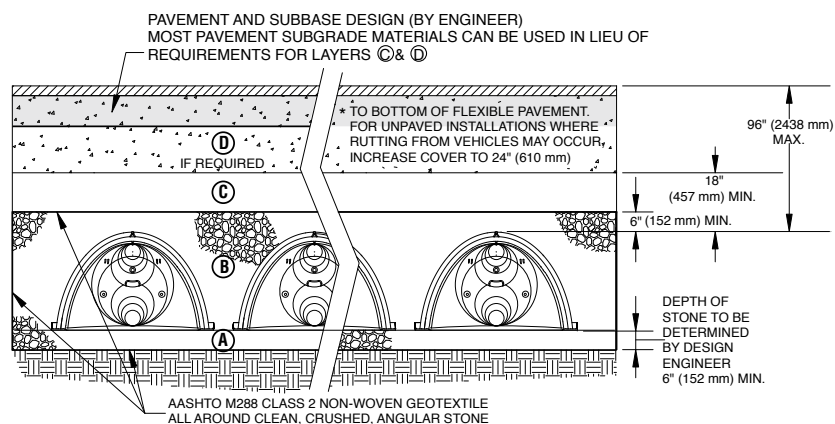
Table 2 – Acceptable Fill Materials

Material Location	Description	AASHTO M43 Designation ¹	Compaction/Density Requirement
Ⓓ Fill Material for layer D starts from the top of the C layer to the bottom of flexible pavement or unpaved finished grade above. Note that pavement sub-base may be part of the D layer.	Any soil/rock materials, native soils or per engineer's plans. Check plans for pavement subgrade requirements.	N/A	Prepare per engineer's plans. Installations may have stringent material and preparation requirements.
Ⓒ Fill Material for layer C starts from the top of the embedment stone (B layer) to 18" (457 mm) above the top of the chamber. Note that pavement sub-base may be part of the C layer.	Granular well-graded soil/aggregate mixtures, <35% fines. Most pavement subgrade materials can be used in lieu of this layer.	3, 357, 4, 467, 5, 56, 57, 6, 67, 68, 7, 78, 8, 89, 9, 10	Begin compaction after 12" (305 mm) of material over the chambers is reached. Compact additional layers in 6" (152 mm) max lifts to a min. 95% Standard Proctor density (see notes). Roller gross vehicle weight not to exceed 12,000 lbs. (53 kN). Dynamic force not to exceed 20,000 lbs. (89 kN).
Ⓑ Embedment Stone surrounding chambers from the foundation stone to the C layer above.	Clean, crushed, angular stone, nominal size distribution 3/4 - 2" (19 mm - 51 mm)	3, 357, 4, 467, 5, 56, 57	No compaction required.
Ⓐ Foundation Stone below the chambers from the subgrade up to the foot (bottom) of the chamber.	Clean, crushed, angular stone, nominal size distribution 3/4 - 2" (19 mm - 51 mm)	3, 357, 4, 467, 5, 56, 57	Plate compact or roll to achieve a 95% Standard Proctor Density (see notes).

PLEASE NOTE: 1. The listed AASHTO designations are for gradations only. The stone must also be clean, crushed, angular. For example, a specification for #4 stone would state: "Clean, crushed, angular no. 4 (AASHTO M43) stone." 2. As an alternate to Proctor Testing and field density measurements on open graded stone, StormTech compaction requirements are met for 'A' location materials when placed and compacted in 9" (229 mm) (max.) lifts using two full passes with an appropriate compactor.

Figure 5 – Fill Material Locations

Once layer C is placed any soil/material can be placed in layer D up to the finished grade. Most pavement subbase soils can be used to replace the materials requirements of layer C or D at the design engineer's discretion.



6.0 Inletting the Chambers

The design flexibility of a Stormtech chamber system includes many inletting possibilities. Contact StormTech's Technical Service Department for guidance on designing an inlet system to meet specific site goals.

6.1 TREATMENT TRAIN

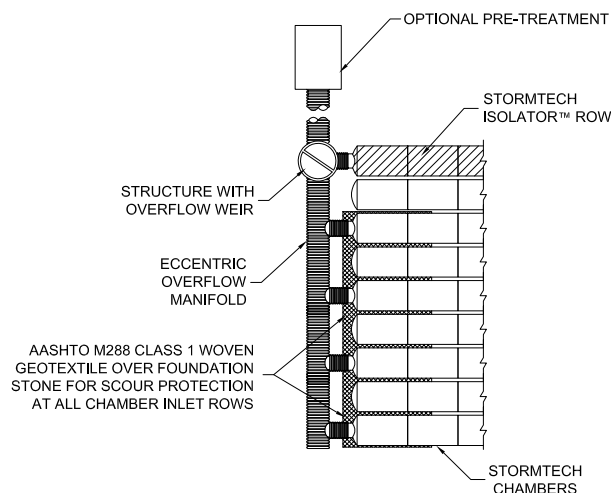
A properly designed inlet system can ensure good water quality, easy inspection and maintenance, and a long system service life. StormTech recommends a treatment train approach for inletting an underground stormwater management system under a typical commercial parking area. *Treatment train* is an industry term for a multi-tiered water quality network. As shown in **Figure 6**, a StormTech recommended inlet system can inexpensively have up to 3 tiers of treatment upstream of the StormTech chambers:

Tier 1 – Pre-treatment (BMP)

Tier 2 – StormTech Isolator Row

Tier 3 – Eccentric Pipe Manifold

Figure 6 – Typical StormTech Treatment Train Inlet System



6.2 PRE-TREATMENT (BMP) – TREATMENT TIER 1

In some areas pre-treatment of the stormwater is required prior to entry into a stormwater system. By treating the stormwater prior to entry into the system, the service life of the system can be extended, pollutants such as hydrocarbons may be captured, and local regulations met. Pre-treatment options are often described as a Best Management Practice or simply a BMP.

Pre-treatment devices differ greatly in complexity, design and effectiveness. Depending on a site's characteristics and treatment goals, the simple, least expensive pre-treatment solutions can sometimes be just as effective as the complex systems. Options include a simple deep sumped manhole with a 90° bend on its outlet, baffle boxes, swirl concentrators, sophisticated filtration

devices, and devices that combine these processes. Some of the most effective pre-treatment options combine engineered site grading with vegetation such as bio-swales or grassy strips.

The type of pretreatment device specified as the first level of treatment up-stream of a StormTech chamber system can vary greatly throughout the country and from site-to-site. It is the responsibility of the design engineer to understand the water quality issues and design a stormwater treatment system that will satisfy local regulators and follow applicable laws. A design engineer should apply their understanding of local weather conditions, site topography, local maintenance requirements, expected service life, etc...to select an appropriate stormwater pre-treatment system.

6.3 STORMTECH ISOLATOR™ ROW – TREATMENT TIER 2

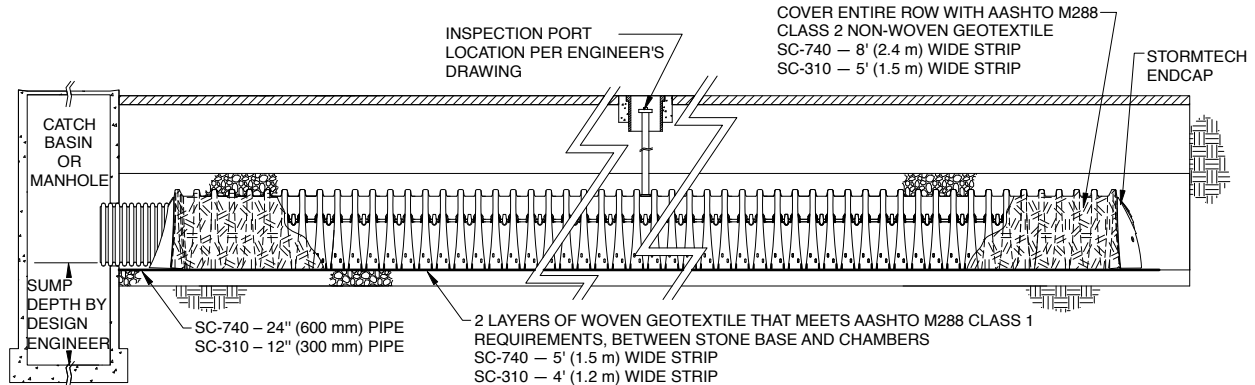
StormTech has a patented technique to inexpensively enhance Total Suspended Solids (TSS) removal and provide easy access for inspection and maintenance. The StormTech Isolator Row is a row of standard StormTech chambers surrounded with appropriate filter fabrics and connected to a manhole for easy access. This application basically creates a filter/detention basin that allows water to egress through the surrounding filter fabric while sediment is trapped within. It may be best to think of the Isolator Row as a first-flush treatment device. *First-Flush* is a term typically used to describe the first ½" to 1" (13-25 mm) of rainfall or runoff on a site. The majority of stormwater pollutants are carried in the sediments of the first-flush, therefore the Isolator Row is an effective component of a treatment train.

The StormTech Isolator Row should be designed with a manhole with an overflow weir at its upstream end. The diversion manhole is multi-purposed. It can provide access to the Isolator Row for both inspection and maintenance and acts as a diversion structure. The manhole is connected to the Isolator Row with a short length of 12" (300 mm) pipe for the SC-310 chamber and 24" (600 mm) pipe for the SC-740 chamber. These pipes are connected to the Isolator Row with a 12" (300 mm) fabricated end cap for the SC-310 chamber and a 24" (600 mm) fabricated end cap for the SC-740 chamber. The overflow weir typically has its crest set between the top of the chamber and its midpoint. This allows stormwater in excess of the Isolator Row's storage/conveyance capacity to bypass into the chamber system through the downstream manifold system.

Specifying and installing proper geotextiles is essential for efficient operation and to prevent damage to the system during the JetVac maintenance process. Two strips of woven geotextile that meets AASHTO M288 Class 1 requirements is required between the chambers and their stone foundation. This strong filter fabric traps

6.0 Inletting the Chambers

Figure 7 – StormTech Isolator™ Row Detail



sediments and protects the stone base during maintenance. A strip of non-woven AASHTO M288 Class 2 geotextile is draped over the Isolator chamber row. This 6-8 oz. (217-278 g/m²) non-woven filter fabric prevents sediments from migrating out of the chambers perforations while allowing modest amounts of water to flow out of the Isolator Row. **Figure 7** is a detail of the Isolator Row that shows proper application of the geotextiles.

Inspection is easily accomplished through the upstream manhole or optional inspection ports. Maintenance of an Isolator Row is fast and easy using the JetVac process through the upstream manhole. Section 13.0 explains the inspection and maintenance process in more detail.

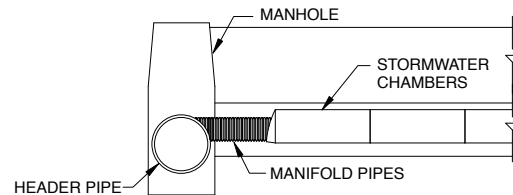
Each SC-740 chamber in an Isolator Row will store 45.9 ft³ (1.3 m³) of first-flush stormwater. During and between storm events an Isolator Row will allow stormwater to egress at a rate of 0.25 cfs (7.1 l/s) or less per chamber. A bed of StormTech chambers may have multiple Isolator Rows to accommodate required first-flush volumes.

6.4 ECCENTRIC MANIFOLD SYSTEM – TREATMENT TIER 3

The third tier of the treatment train is the eccentric manifold system. This is much like a typical manifold system except that the inlet pipe stubs are smaller and located at a higher invert than the main trunk of the manifold. This is accomplished by building the manifold system with reducer tees installed upside down so a “sump” is created within the large diameter header pipe as shown in **Figure 8**. A typical eccentric system might have a 48" (1200 mm) pipe with 18" (450 mm) manifolds creating a 30" (750 mm) header sump.

The upstream end of the eccentric manifold system will typically be connected directly to the downstream side of the Isolator Row's weired manhole as shown in **Figure 6**. Pipe companies can provide more detailed information on designing a header system optimized for trapping TSS.

Figure 8 – Typical Eccentric Header System



6.5 TREATMENT TRAIN CONCLUSION

The treatment train is a highly effective water-quality approach that does not add significant cost to a StormTech system being installed under commercial parking areas. The StormTech Isolator Row adds a significant level of treatment, easy inspection and maintenance, while maintaining storage volume credit for the cost of a modest amount of geotextile. Finally, a pipe manifold system is a well recognized component of a chamber inlet system. Inverting the reducer tees creates an eccentric manifold system that can be easily inspected and maintained. This treatment train concept provides three levels of treatment, inspection and maintenance upstream of the StormTech detention/retention bed with little additional expense.

6.6 OTHER INLET OPTIONS

While the three-tiered treatment train approach is the recommended method of inletting StormTech chambers for typical under-commercial parking applications, there are other effective inlet methods that may be considered. For instance, Isolator Rows, while adding an inexpensive level of confidence, are not always necessary. A header system with fewer inlets can be designed to further minimize the cost of a StormTech system. There may be applications where stormwater pre-treatment may not be necessary at all and the system can be inlet directly from the source. Contact StormTech's Technical Service Department to discuss inlet options.

6.0 Inletting the Chambers

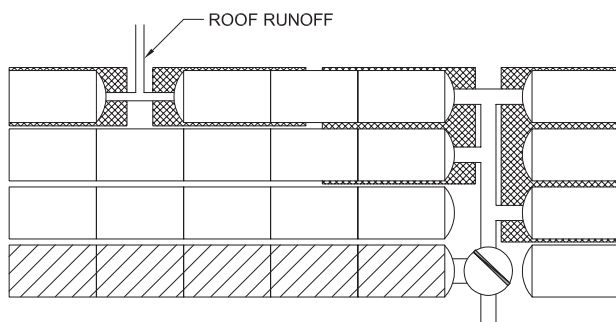
6.7 LATERAL FLOW RATES

The embedment stone surrounding the StormTech chambers allows the rapid conveyance of stormwater between chamber rows. Stormwater will rise and fall evenly within a bed of chambers. A single StormTech chamber is able to release or accept stormwater at a rate of at least 0.5 cfs (14.2 l/s) through the surrounding stone.

6.8 INLETING PERPENDICULAR TO A ROW OF CHAMBERS

There is an easy, inexpensive method to perpendicularly inlet a row of chambers. Simply replace the chamber with a tee where the inlet pipe intersects the row. From the tee, short lengths of pipe may be used to penetrate the endcaps used to terminate the two new openings in the row. **Figure 9** is a typical detail of the perpendicular inlet methods.

Figure 9 – Perpendicular Inlet



6.9 MAXIMUM INLET PIPE VELOCITIES TO PREVENT SCOURING OF THE STONE FOUNDATION

This section is applicable to the classic manifold and emergency overflow inlet piping. Isolator Rows are protected from scouring by the woven geotextile.

To prevent scouring of the foundation stone, inlet pipe flow velocities must not exceed those listed in **Table 3**. Flow velocities greater than those listed may cause excess scouring at the inlet water's impact zone, which can be detrimental to the stone's performance as a structural foundation. In these cases, scour control measures must be implemented. Simple scour control measures include applying rip-rap, geotextile material or splash dissipators to the inlet water's projected impact zone. Many designers implement scour control measures as a general practice, regardless of flow velocity. StormTech recommends 12.5' (3.8 m) of AASHTO M288 Class 1 woven geotextile at each inlet row.

Table 3 – Maximum Inlet Velocity in Feet Per Second to Prevent Scouring of an Unprotected 3/4" to 2" (19 mm to 50 mm) Angular Stone Foundation

Inlet Pipe Diameter in. (mm)	Maximum Inlet Pipe Velocities feet per second (meters per second)
4 (100)	2.43 (0.74)
6 (150)	2.61 (0.80)
8 (200)	2.73 (0.83)
10 (250)	2.44 (0.74)
12 (300)	2.19 (0.67)
15 (375)	2.00 (0.61)
18 (450)	1.88 (0.57)
24 (600)	1.74 (0.53)

Table 4 – Some Suitable Geotextiles

Manufacturer	AASHTO M288 Class 2 Non-Woven*	AASHTO M288 Class 1 Woven**
Belton Industries	—	Beltech 977
Carthage Mills	FX-60HS, FX-80HS	FX-66
Contech Const. Products GSE Lining Technology	NW6, NW8	—
Maccaferri	MacTex MX245 MacTex MX275	—
Pavco - Amanco	NT 3000, NT 4000	TR 4000
Propex	Geotex 651 Geotex 861 Geotex 601 Geotex 701 Geotex 801	Geotext 315ST Geotex 2X2HF Geotex 250ST
SKAPS Industries	GT 160NW GT 180NW	W315
Tencate Mirafi	Mirafi 160N Mirafi 180N	Mirafi 600X Filterweave 403 Filterweave 404 Geolon HP570 Geolon HP665 Geolon HP770
TNS Advanced Tech.	R 060, R070 R 080, R100	—
US Fabrics	US 205NW-C, US160NW	US 315

*AASHTO M288 Class 2 Non-Woven Geotextile Application: 1. Separation layer between angular stone cover and fill to prevent fines intrusion. 2. Filter layer over the chambers of the StormTech Isolator™ Row to prevent fines migration out of row while maintaining adequate hydraulic flows.

**AASHTO M288 Class 1 Woven Geotextile Application: 1. Stabilization layer for the angular stone foundation of the StormTech Isolator™ Row to prevent scouring of the foundation stone during the JetVac maintenance procedure, modest hydraulic flows maintained. 2. At each inlet row to prevent scouring of the foundation stone.

7.0 Outlets for Chambers



7.0 OUTLETS FOR STORMTECH CHAMBER SYSTEMS

The majority of StormTech installations are detention systems and have some type of outlet structure. An outlet manifold is generally designed to ensure that peak flows can be conveyed to the outlet structure.

To drain the system completely, an underdrain system is located at or below the bottom of the foundation stone. Although it's not usually necessary, some beds may be designed with a pitched base to ensure complete drainage of the system. A grade of 1/2% is usually satisfactory.

An outlet pipe may be located at a higher invert within a bed. This allows a designed volume of water to infiltrate while excess volumes are outlet as necessary. This is an excellent method of recharging groundwater, replicating a site's pre-construction hydraulics.

Depending on the bed layout and inverts, outlet pipes should be placed in the embedment stone along the bed's perimeter as shown in **Figures 10** and **11**. Solid outlet pipes may also be used to penetrate the StormTech end caps at the designed outlet invert as shown in **Figure 12**. An Isolator Row should not be directly penetrated with an outlet pipe. For systems requiring higher outlet flow rates, a combination of connections may be utilized as shown in **Figure 13**.

In detention and retention applications the discharge of water from the stormwater management system is determined based on the hydrology of the area and the hydraulic design of the system. It is the design engineer's responsibility to design an outlet system that meets their hydraulic objectives while following local laws and regulations.

Figure 10 – Underdrain Parallel

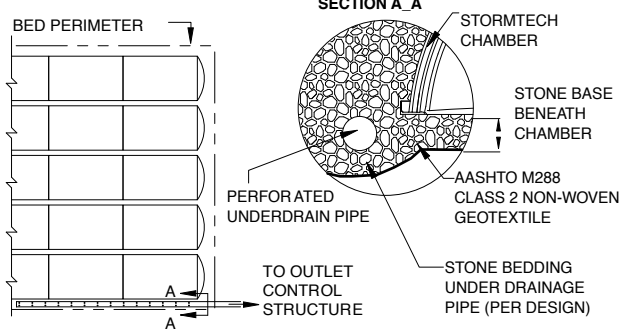


Figure 11 – Underdrain Perpendicular

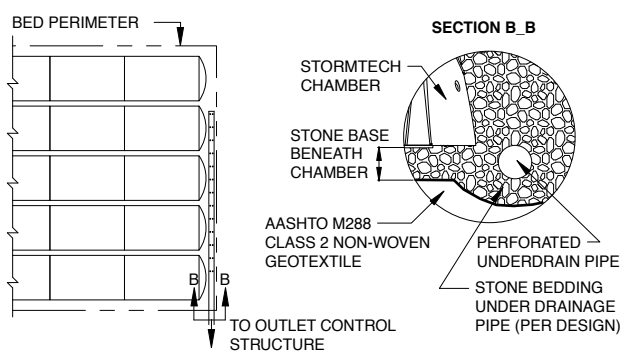


Figure 12 – Outlet Manifold

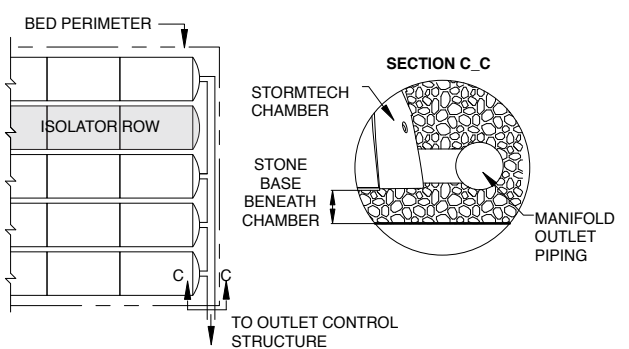
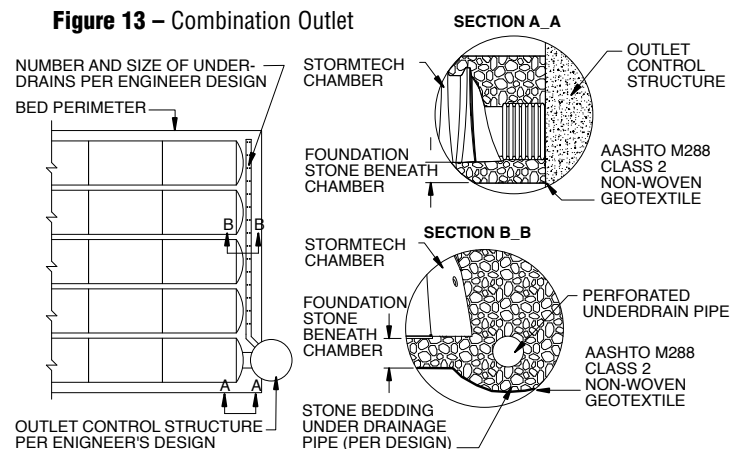


Figure 13 – Combination Outlet



8.0 Cumulative Storage Volumes

Table 5 and **Table 6** provide cumulative storage volumes for SC-310 and SC-740 chamber systems. This information may be used to calculate a detention/retention system's stage storage volume. A spreadsheet is available at www.stormtech.com in which the number of chambers can be input for quick cumulative storage calculations

Product Specifications: 1.1, 2.2, 2.3, 2.4 and 2.6

TABLE 5 – SC-310 Cumulative Storage Volumes Per Chamber
Assumes 40% Stone Porosity. Calculations are Based Upon a 6" (152 mm) Stone Base Under the Chambers.

Depth of Water in System Inches (mm)	Cumulative Chamber Storage ft ³ (m ³)	Total System Cumulative Storage ft ³ (m ³)
28 (711)	↑ 14.70 (0.416)	31.00 (0.878)
27 (686)	↑ 14.70 (0.416)	30.21 (0.855)
26 (680)	Stone 14.70 (0.416)	29.42 (0.833)
25 (610)	Cover 14.70 (0.416)	28.63 (0.811)
24 (609)	↓ 14.70 (0.416)	27.84 (0.788)
23 (584)	↓ 14.70 (0.416)	27.05 (0.766)
22 (559)	14.70 (0.416)	26.26 (0.748)
21 (533)	14.64 (0.415)	25.43 (0.720)
20 (508)	14.49 (0.410)	24.54 (0.695)
19 (483)	14.22 (0.403)	23.58 (0.668)
18 (457)	13.68 (0.387)	22.47 (0.636)
17 (432)	12.99 (0.368)	21.25 (0.602)
16 (406)	12.17 (0.345)	19.97 (0.566)
15 (381)	11.25 (0.319)	18.62 (0.528)
14 (356)	10.23 (0.290)	17.22 (0.488)
13 (330)	9.15 (0.260)	15.78 (0.447)
12 (305)	7.99 (0.227)	14.29 (0.425)
11 (279)	6.78 (0.192)	12.77 (0.362)
10 (254)	5.51 (0.156)	11.22 (0.318)
9 (229)	4.19 (0.119)	9.64 (0.278)
8 (203)	2.83 (0.081)	8.03 (0.227)
7 (178)	1.43 (0.041)	6.40 (0.181)
6 (152)	↑ 0	4.74 (0.134)
5 (127)	↑ 0	3.95 (0.112)
4 (102)	Stone 0	3.16 (0.090)
3 (76)	Foundation 0	2.37 (0.067)
2 (51)	↓ 0	1.58 (0.046)
1 (25)	↓ 0	0.79 (0.022)

Note: Add 0.79 ft³ (0.022 m³) of storage for each additional inch (25 mm) of stone foundation.

TABLE 6 – SC-740 Cumulative Storage Volumes Per Chamber
Assumes 40% Stone Porosity. Calculations are Based Upon a 6" (152 mm) Stone Base Under the Chambers.

Depth of Water in System Inches (mm)	Cumulative Chamber Storage Ft ³ (m ³)	Total System Cumulative Storage Ft ³ (m ³)
42 (1067)	↑ 45.90 (1.300)	74.90 (2.121)
41 (1041)	↑ 45.90 (1.300)	73.77 (2.089)
40 (1016)	Stone 45.90 (1.300)	72.64 (2.057)
39 (991)	Cover 45.90 (1.300)	71.52 (2.025)
38 (965)	↓ 45.90 (1.300)	70.39 (1.993)
37 (948)	↓ 45.90 (1.300)	69.26 (1.961)
36 (914)	45.90 (1.300)	68.14 (1.929)
35 (889)	45.85 (1.298)	66.98 (1.897)
34 (864)	45.69 (1.294)	65.75 (1.862)
33 (838)	45.41 (1.286)	64.46 (1.825)
32 (813)	44.81 (1.269)	62.97 (1.783)
31 (787)	44.01 (1.246)	61.36 (1.737)
30 (762)	43.06 (1.219)	59.66 (1.689)
29 (737)	41.98 (1.189)	57.89 (1.639)
28 (711)	40.80 (1.155)	56.05 (1.587)
27 (686)	39.54 (1.120)	54.17 (1.534)
26 (660)	38.18 (1.081)	52.23 (1.479)
25 (635)	36.74 (1.040)	50.23 (1.422)
24 (610)	35.22 (0.977)	48.19 (1.365)
23 (584)	33.64 (0.953)	46.11 (1.306)
22 (559)	31.99 (0.906)	44.00 (1.246)
21 (533)	30.29 (0.858)	41.85 (1.185)
20 (508)	28.54 (0.808)	39.67 (1.123)
19 (483)	26.74 (0.757)	37.47 (1.061)
18 (457)	24.89 (0.705)	35.23 (0.997)
17 (432)	23.00 (0.651)	32.96 (0.939)
16 (406)	21.06 (0.596)	30.68 (0.869)
15 (381)	19.09 (0.541)	28.36 (0.803)
14 (356)	17.08 (0.484)	26.03 (0.737)
13 (330)	15.04 (0.426)	23.68 (0.670)
12 (305)	12.97 (0.367)	21.31 (0.608)
11 (279)	10.87 (0.309)	18.92 (0.535)
10 (254)	8.74 (0.247)	16.51 (0.468)
9 (229)	6.58 (0.186)	14.09 (0.399)
8 (203)	4.41 (0.125)	11.66 (0.330)
7 (178)	2.21 (0.063)	9.21 (0.264)
6 (152)	↑ 0	6.76 (0.191)
5 (127)	↑ 0	5.63 (0.160)
4 (102)	Stone 0	4.51 (0.125)
3 (76)	Foundation 0	3.38 (0.095)
2 (51)	↓ 0	2.25 (0.064)
1 (25)	↓ 0	1.13 (0.032)

Note: Add 1.13 ft³ (0.032 m³) of storage for each additional inch (25 mm) of stone foundation.



9.0 Other Considerations

9.1 EROSION CONTROL

Erosion and sediment control measures must be integrated into the plan to protect the stormwater system both during and after construction. These practices may have a direct impact on the system's infiltration performance and longevity. Vegetation, temporary sediment barriers (silt fences, hay bales, fabric-wrapped catch basin grates), and strategic stormwater runoff management may be used to control erosion and sedimentation. StormTech recommends the use of pipe plugs on the inlet pipe until the system is in service.

9.2 SITE IMPROVEMENT TECHNIQUES

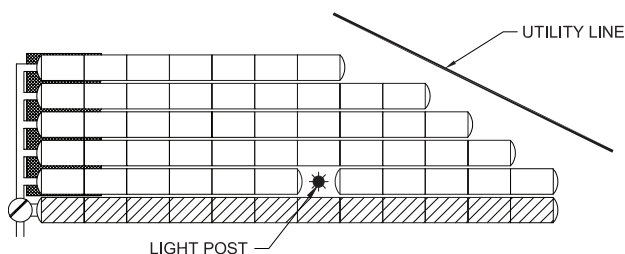
When site conditions are less than optimal, StormTech recognizes many methods for improving a site for construction. Some techniques include the removal and replacement of poor materials, the use of engineered subgrade materials, aggregates, chemical treatment, and mechanical treatments including the use of geosynthetics. StormTech recommends referring to AASHTO M-288 guidelines for the appropriate use of geotextiles.

StormTech also recognizes geogrid as a potential component of an engineered solution to improve site conditions or as a construction tool for the experienced contractor. StormTech chamber systems are compatible with the use of geosynthetics. The use of geosynthetics or any other site improvement method does not eliminate or modify any of StormTech's requirements. **It is the ultimate responsibility of the design engineer to ensure that site conditions are suitable for a StormTech chamber system.**

9.3 CONFORMING TO SITE CONSTRAINTS

StormTech chambers have the unique ability to conform to site constraints such as utility lines, light posts, large trees, etc. Rows of chambers can be ended short or interrupted by placing an end cap at the desired location, leaving the required number of chambers out of the row to get by the obstruction, then starting the row of chambers again with another end cap. See **Figure 14** for an example.

Figure 14 – Ability to Conform to Site Constraints



9.4 LINERS

StormTech chambers offer the distinct advantage and versatility that allow them to be designed as an open bottom detention or retention system. In fact, the vast majority of StormTech installations and designs are open bottom detention systems. Using an open bottom system enables treatment of the storm water through the underlying soils and provides a volume safety factor based on the infiltrative capacity of the underlying soils.

In some applications, however, open bottom detention systems may not be allowed. StormTech's Tech Sheet #2 provides guidance for the design and installation of thermoplastic liners for detention systems using StormTech chambers. The major points of the memo are:

- Infiltration of stormwater is generally a desirable stormwater management practice, often required by regulations. Lined systems should only be specified where unique site conditions preclude significant infiltration.
- Thermoplastic liners provide cost effective and viable means to contain stormwater in StormTech sub-surface systems where infiltration is undesirable.
- PVC and LLDPE are the most cost effective, installed membrane materials.
- Enhanced puncture resistance from angular aggregate on the water side and from protrusions on the soil side can be achieved by placing a non-woven geotextile reinforcement on each side of the geomembrane. A sand underlayment in lieu of the geotextile reinforcement on the soil side may be considered when cost effective.
- StormTech does not design, fabricate, sell or install thermoplastic liners. StormTech recommends consulting with liner professionals for final design and installation advice.

Figure 15 – Chamber bed placed around light post.



10.0 System Sizing

For quick calculations, refer to the Site Calculator on StormTech's website at www.stormtech.com.

10.1 SYSTEM SIZING

The following steps provide the calculations necessary to size a system. The worksheet on page 17 itemizes these calculations and costs. If you need assistance determining the number of chambers per row or customizing the bed configuration to fit a specific site, call StormTech's Technical Services Department at **1-888-892-2694**.

1) Determine the amount of storage volume (V_s) required.

It is the design engineer's sole responsibility to determine the storage volume required by local codes.

TABLE 7 – Storage Volume Per Chamber

	Bare Chamber Storage ft ³ (m ³)	Chamber and Stone Foundation Depth in. (mm)		
		6 (152)	12 (305)	18 (457)
StormTech SC-740	45.9 (1.3)	74.9 (2.1)	81.7 (2.3)	88.4 (2.5)
StormTech SC-310	14.7 (0.4)	31.0 (0.9)	35.7 (1.0)	40.4 (1.1)

Note: Storage volumes are in cubic feet per chamber. Assumes 40% porosity for the stone plus the chamber volume.

2) Determine the number of chambers (C) required.

To calculate the number of chambers needed for adequate storage, divide the storage volume (V_s) by the volume of the selected chamber, as follows:

$$C = V_s / \text{Volume per Chamber}$$

3) Determine the required bed size (S).

To find the size of the bed, multiply the number of chambers needed (C) by either:

StormTech SC-740

bed area per chamber = 33.8 ft² (3.1 m²)

StormTech SC-310

bed area per chamber = 23.7 ft² (2.2 m²)

$$S = (C \times \text{bed area per chamber}) + [1 \text{ foot (0.3 m)} \times \text{bed perimeter in feet (meters)}]$$

NOTE: It is necessary to add one foot (0.3 m) around the perimeter of the bed for end caps and working space.

4) Determine the amount of clean, crushed, angular stone (V_{st}) required.

TABLE 8 – Amount of Stone Per Chamber in Tons (kg)

ENGLISH	Stone Foundation Depth		
	6"	12"	18"
StormTech SC-740	3.8 (2.8 yd ³)	4.6 (3.3 yd ³)	5.5 (3.9 yd ³)
StormTech SC-310	2.1 (1.5 yd ³)	2.7 (1.9 yd ³)	3.4 (2.4 yd ³)
METRIC	152 mm	305 mm	457 mm
StormTech SC-740	3450 (2.1 m ³)	4170 (2.5 m ³)	4490 (3.0 m ³)
StormTech SC-310	1830 (1.1 m ³)	2490 (1.5 m ³)	2990 (1.8 m ³)

Note: Assumes 6" (152 mm) of stone above, and between chambers.

To calculate the total amount of clean, crushed, angular stone required, multiply the number of chambers (c) by the selected weight of stone from **Table 8**.

NOTE: Clean, crushed, angular stone is also required around the perimeter of the system.

5) Determine the volume of excavation (E_x) required. 6) Determine the area of filter fabric (F) required.

TABLE 9 – Volume of Excavation Per Chamber

	Stone Foundation Depth		
	6" (152 mm)	12" (305 mm)	18" (457 mm)
StormTech SC-740	5.5 (4.2)	6.2 (4.7)	6.8 (5.2)
StormTech SC-310	2.9 (2.2)	3.4 (2.6)	3.8 (2.9)

Note: Volumes are in cubic yards (cubic meters) per chamber. Assumes 6" (152 mm) of separation between chamber rows and 18" (457 mm) of cover. The volume of excavation will vary as the depth of the cover increases.

Each additional foot of cover will add a volume of excavation of 1.3 yds³ (1.0 m³) per SC-740 and 0.9 yds³ (0.7 m³) per SC-310 chamber.

The bottom and sides of the bed and the top of the embedment stone must be covered with a non-woven geotextile (filter fabric) that meets AASHTO M288 Class 2 requirement. The area of the sidewalls must be calculated and a 2 foot (0.6 m) overlap must be included where two pieces of filter fabric are placed side-by-side or end-to-end. Geotextiles typically come in 15 foot (4.6 m) wide rolls.

7) Determine the number of end caps (E_c) required.

Each row of chambers requires two end caps.

$$E_c = \text{number of rows} \times 2$$

11.0 Materials Worksheet



Project _____

Location _____

By _____

SYSTEM REQUIREMENTS		STORMTECH SC-310	STORMTECH SC-740
1. Required storage volume (V_s)	V_s	____ ft ³ (m ³)	____ ft ³ (m ³)
2. Number of chambers (C) required:	C	____ (V_s) / chamber storage	____ (V_s) / chamber storage
3. Required bed size (S):	S	____ [(C) x 23.7 ft ²] + (1 ft. x bed perimeter) ____ [(C) x 2.2 m ²] + (0.3 m x bed perimeter)	____ [(C) x 33.8 ft ²] + (1 ft. x bed perimeter) ____ [(C) x 3.1 m ²] + (0.3 m x bed perimeter)
4. Tons of stone (V_{st}) required:	V_{st}	____ Number from Table 8 x (C)	____ Number from Table 8 x (C)
5. Volume of excavation (E_x):	E_x	____ Number from Table 9 x (C)	____ Number from Table 9 x (C)
6. Area of filter fabric (F) required =	F	____ yd ² (m ²)	____ yd ² (m ²)
7. Quantity of end caps required [2 x number of rows (E_c):]	E_c	____ End caps	____ End caps

Note: Round up to the nearest whole number.

SYSTEM COST

	Quantity	Cost	Total
Chambers (C)	_____ x	\$ _____/Chamber =	\$ _____
Stone (T_{st})	_____ x	\$ _____/Tons (kg) =	\$ _____
Excavation (E_x)	_____ x	\$ _____/yd ³ (m ³) =	\$ _____
Filter fabric (F)	_____ x	\$ _____/yd ² (m ²) =	\$ _____
End caps (E_c)	_____ x	\$ _____/End caps =	\$ _____
SUBTOTAL* :			\$ _____
COST PER FT³ (m³) (subtotal ÷ required storage (V_s)):			\$ _____

Refer to StormTech's website www.stormtech.com for an interactive version of this worksheet.

* Chamber costs may not be inclusive of shipping. For general estimate purposes only. Calculations do not reflect changes in geographical costs or contractor's overhead, profit and other miscellaneous expenses.

12.0 Detail Drawings

Figure 16 – Plan View Detail – StormTech Chambers (not to scale)

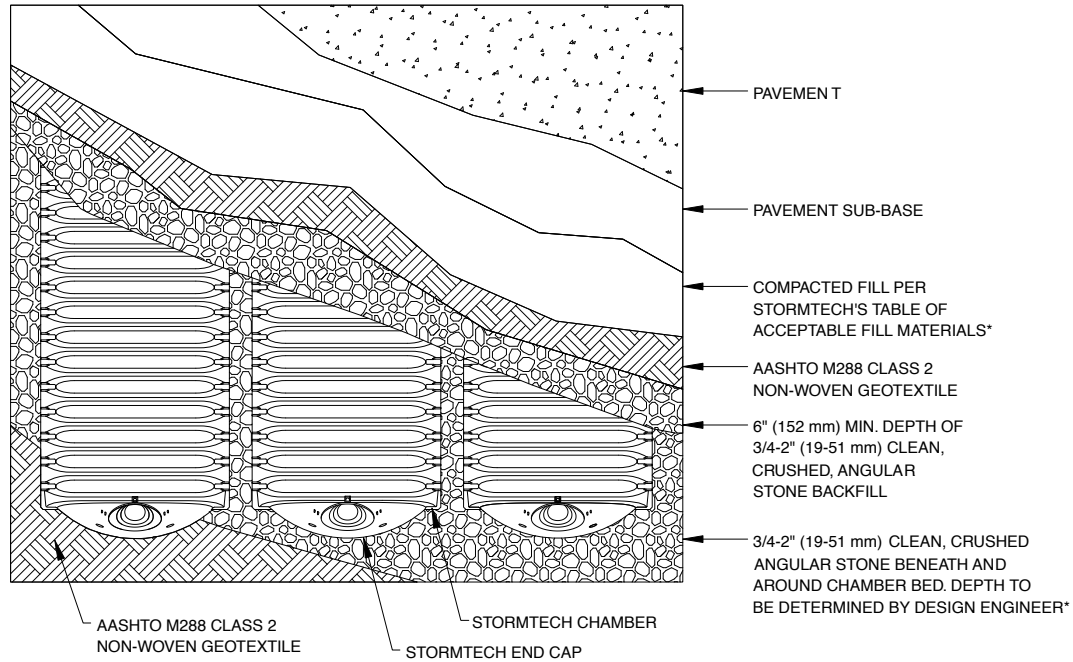
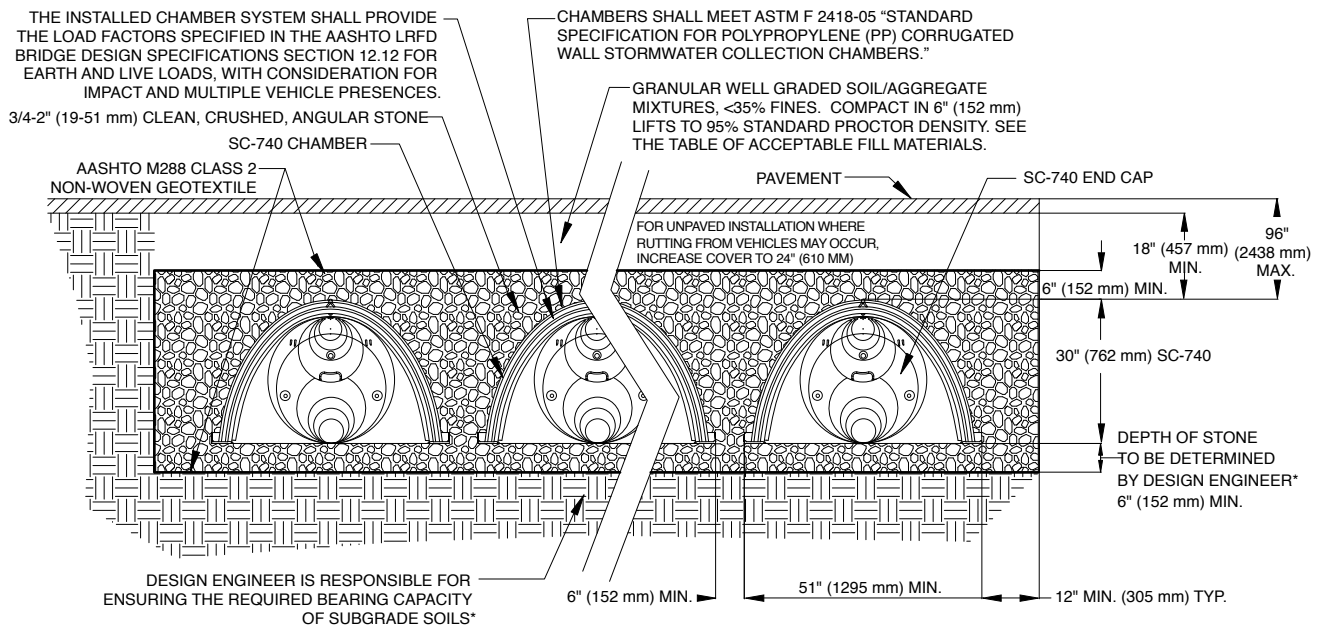


Figure 17 – Typical Cross Section Detail – StormTech Chambers (not to scale)



THIS CROSS SECTION DETAILS THE REQUIREMENTS NECESSARY TO SATISFY THE LOAD FACTORS SPECIFIED IN THE AASHTO LRFD BRIDGE DESIGN SPECIFICATIONS SECTION 12.12 FOR EARTH AND LIVE LOADS USING STORMTECH CHAMBERS

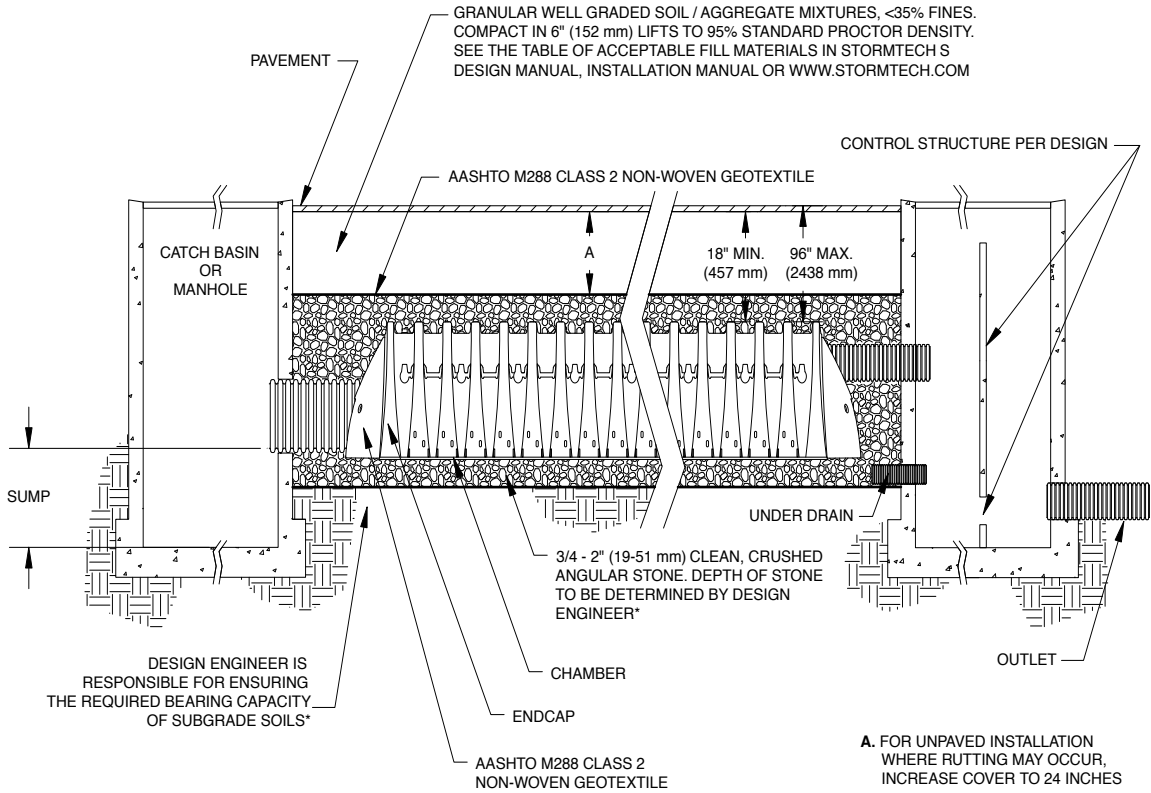
*See Section 4 of this Design Manual.

Detail drawings available in AutoCad Rev. 2000 format at www.stormtech.com.

12.0 Detail Drawings

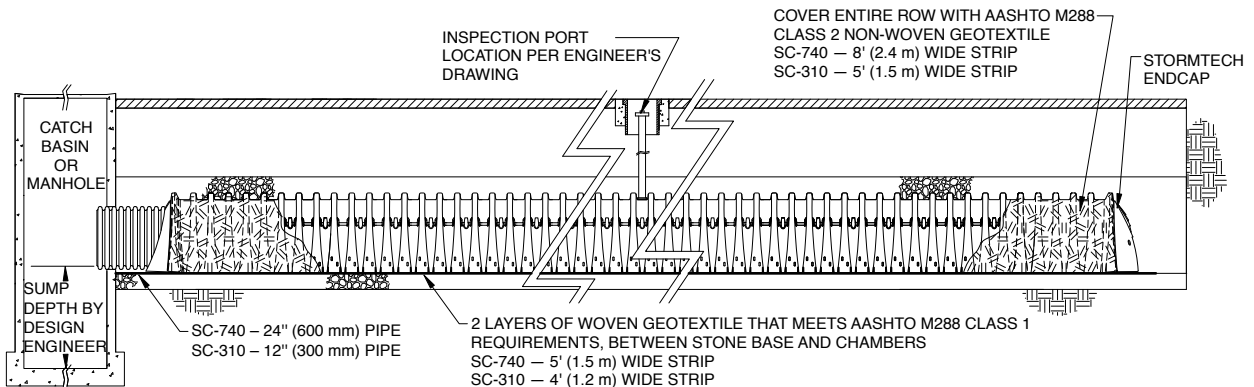


Figure 18 – Inlet and Outlet Detail – StormTech Non-Isolator Row (not to scale)



*See Section 4 of this Design Manual.

Figure 19 – StormTech Isolator™ Row (not to scale)

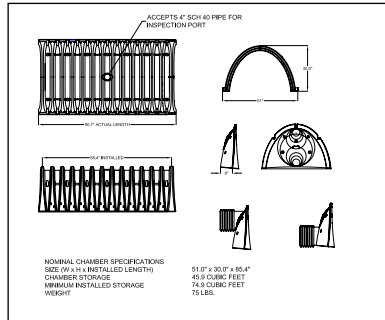


Detail drawings available in AutoCad Rev. 2000 format at www.stormtech.com.

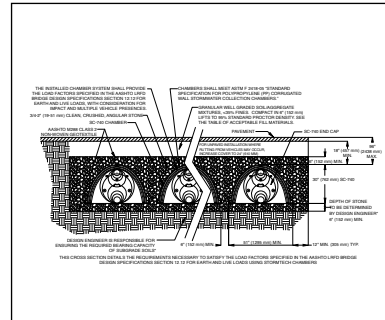
12.0 Detail Drawings

12.0 AVAILABLE DETAIL DRAWINGS

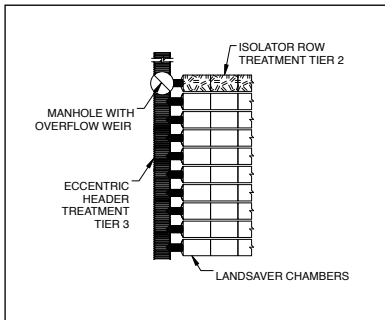
Below are examples of some of the CAD and PDF drawings that are available at www.stormtech.com.



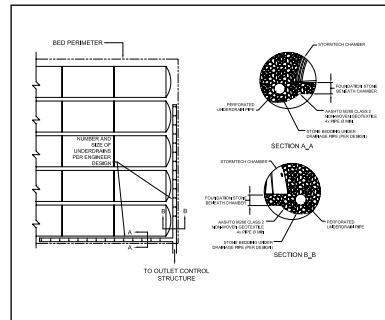
Technical Specifications



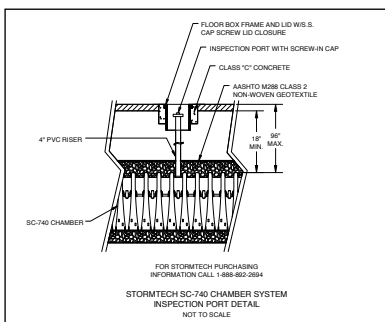
Typical Cross Section



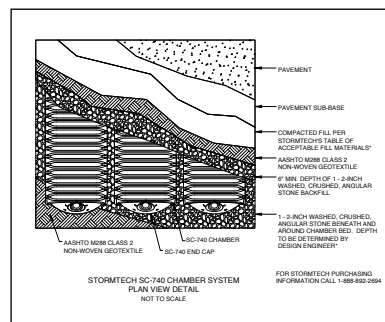
Classic Manifold Detail



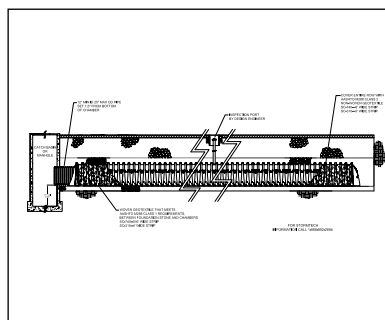
Underdrain Detail



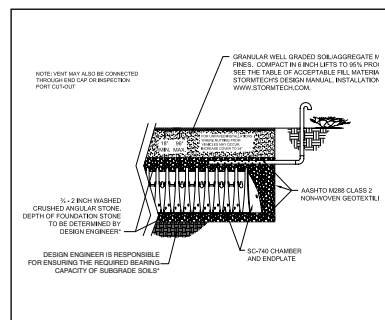
Inspection Port Detail



Plan View Detail



Isolator Profile View



Vent Detail

13.0 Inspection and Maintenance

13.1 ISOLATOR™ ROW INSPECTION

Regular inspection and maintenance are essential to assure a properly functioning stormwater system. Inspection is easily accomplished through the manhole or optional inspection ports of an Isolator Row. Please follow local and OSHA rules for a confined space entry.

Inspection ports can allow inspection to be accomplished completely from the surface without the need for a confined space entry. Inspection ports provide visual access to the system with the use of a flashlight. A stadia rod may be inserted to determine the depth of sediment. If upon visual inspection it is found that sediment has accumulated to an average depth exceeding 3" (76 mm), cleanout is required.

A StormTech Isolator Row should initially be inspected immediately after completion of the site's construction. While every effort should be made to prevent sediment from entering the system during construction, it is during this time that excess amounts of sediments are most likely to enter any stormwater system. Inspection and maintenance, if necessary, should be performed prior to passing responsibility over to the site's owner. Once in normal service, a StormTech Isolator Row should be inspected bi-annually until an understanding of the sites characteristics is developed. The site's maintenance manager can then revise the inspection schedule based on experience or local requirements.

13.2 ISOLATOR ROW MAINTENANCE

JetVac maintenance is recommended if sediment has been collected to an average depth of 3" (76 mm) inside the Isolator Row. More frequent maintenance may be required to maintain minimum flow rates through the Isolator Row. The JetVac process utilizes a high pressure water nozzle to propel itself down the Isolator Row while scouring and suspending sediments. As the nozzle is retrieved, a wave of suspended sediments is flushed back into the manhole for vacuuming. Most sewer and pipe maintenance companies have vacuum/ JetVac combination vehicles. Fixed nozzles designed for culverts or large diameter pipe cleaning are preferable. Rear facing jets with an effective spread of at least 45° (1143 mm) are best. The JetVac process shall only be performed on StormTech Rows that have AASHTO class 1 woven geotextile over their foundation stone.



Looking down the Isolator Row.



A typical JetVac truck. (This is not a StormTech product.)



Examples of culvert cleaning nozzles appropriate for Isolator Row maintenance. (These are not StormTech products.)

13.0 Inspection & Maintenance

STORMTECH ISOLATOR™ ROW - STEP-BY-STEP MAINTENANCE PROCEDURES

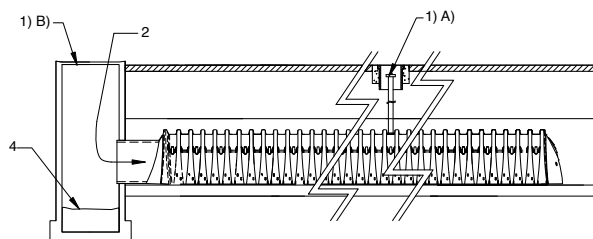
- Step 1)** Inspect Isolator Row for sediment
- A) Inspection ports (if present)
 - i. Remove lid from floor box frame
 - ii. Remove cap from inspection riser
 - iii. Using a flashlight and stadia rod, measure depth of sediment
 - iv. If sediment is at, or above, 3" (76 mm) depth proceed to Step 2. If not proceed to Step 3.
 - B) All Isolator Rows
 - i. Remove cover from manhole at upstream end of Isolator Row
 - ii. Using a flashlight, inspect down Isolator Row through outlet pipe
 - 1. Follow OSHA regulations for confined space entry if entering manhole
 - 2. Mirrors on poles or cameras may be used to avoid a confined space entry
 - iii. If sediment is at or above the lower row of sidewall holes [approximately 3" (76 mm)] proceed to Step 2. If not proceed to Step 3.

- Step 2)** Clean out Isolator Row using the JetVac process
- A) A fixed culvert cleaning nozzle with rear facing nozzle spread of 45" (1143 mm) or more is preferable
 - B) Apply multiple passes of JetVac until back-flush water is clean
 - C) Vacuum manhole sump as required during jetting

Step 3) Replace all caps, lids and covers

Step 4) Inspect and clean catch basins and manholes upstream of the StormTech system following local guidelines.

Figure 20 – StormTech Isolator Row (not to scale)



13.3 ECCENTRIC PIPE HEADER INSPECTION

These guidelines do not supercede a pipe manufacturer's recommended I&M procedures. Consult with the manufacturer of the pipe header system for specific I&M procedures. Inspection of the header system should be carried out quarterly. On sites which generate higher levels of sediment more frequent inspections may be necessary. Headers may be accessed through risers, access ports or manholes. Measurement of sediment may be taken with a stadia rod or similar device. Clean-out of sediment should occur when the sediment volume has reduced the storage area by 25% or the depth of sediment has reached approximately 25% of the diameter of the structure.

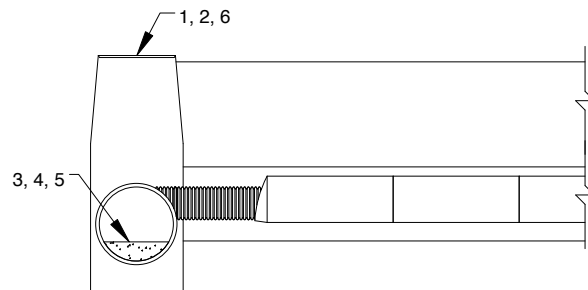
13.4 ECCENTRIC PIPE MANIFOLD MAINTENANCE

Cleanout of accumulated material should be accomplished by vacuum pumping the material from the header. Cleanout should be accomplished during dry weather. Care should be taken to avoid flushing sediments out through the outlet pipes and into the chamber rows.

Eccentric Header Step-by-Step Maintenance Procedures

1. Locate manholes connected to the manifold system
2. Remove grates or covers
3. Using a stadia rod, measure the depth of sediment
4. If sediment is at a depth of about 25% pipe volume or 25% pipe diameter proceed to step 5. If not proceed to step 6.
5. Vacuum pump the sediment. Do not flush sediment out inlet pipes.
6. Replace grates and covers
7. Record depth and date and schedule next inspection

Figure 21 – Eccentric Manifold Maintenance



Please contact StormTech's Technical Services Department at 888-892-2894 for a spreadsheet to estimate cleaning intervals.

14.0 General Notes



1. StormTech LLC (“StormTech”) requires installing contractors to use and understand StormTech’s latest Installation Instructions prior to beginning system installation.
2. Our Technical Services Department offers installation consultations to installing contractors. Contact our Technical Service Representatives at least 30 days prior to system installation to arrange a pre-installation consultation. Our representatives can then answer questions or address comments on the StormTech chamber system and inform the Installing contractor of the minimum installation requirements before beginning the system’s construction. Call **860-529-8188** to speak to a Technical Service Representative or visit **www.stormtech.com** to receive a copy of our Installation Instructions.
3. StormTech’s requirements for systems with pavement design (asphalt, concrete pavers, etc.): Minimum cover is 18" (457 mm) not including pavement; Maximum cover is 96" (2438 mm) including pavement design. For installations that do not include pavement, where rutting from vehicles may occur, minimum required cover is 24" (610 mm), maximum cover is 96" (2438 mm).
4. The contractor must report any discrepancies with the bearing capacity of the chamber foundation materials to the design engineer.
5. AASHTO M288 Class 2 non-woven geotextile (filter fabric) must be used as indicated in the project plans.
6. Stone placement between chamber rows and around perimeter must follow instructions as indicated in the most current version of StormTech’s Installation Instructions.
7. Backfilling over the chambers must follow requirements as indicated in the most current version of StormTech’s Installation Instructions.
8. The contractor must refer to StormTech’s Installation Instructions for a Table of Acceptable Vehicle Loads at various depths of cover. This information is also available at StormTech’s website: **www.stormtech.com**. The contractor is responsible for preventing vehicles that exceed StormTech’s requirements from traveling across or parking over the stormwater system. Temporary fencing, warning tape and appropriately located signs are commonly used to prevent unauthorized vehicles from entering sensitive construction areas.
9. The contractor must apply erosion and sediment control measures to protect the stormwater system during all phases of site construction per local codes and design engineer’s specifications.
10. STORMTECH PRODUCT WARRANTY IS LIMITED. Contact StormTech for warranty information.

15.0 StormTech Product Specifications

1.0 GENERAL

1.1 StormTech chambers are designed to control stormwater runoff. As a subsurface retention system, StormTech chambers retain and allow effective infiltration of water into the soil. As a subsurface detention system, StormTech chambers detain and allow for the metered flow of water to an outfall.

2.0 CHAMBER PARAMETERS

- 2.1 The Chamber shall be injection molded of Polypropylene resin to be inherently resistant to environmental stress cracking (ESCR), and to maintain adequate stiffness through higher temperatures experienced during installation and service.
- 2.2 The nominal chamber dimensions of the StormTech SC-740 shall be 30.0" (762 mm) tall, 51.0" (1295 mm) wide and 90.7" (2304 mm) long. The nominal chamber dimensions of the StormTech SC-310 shall be 16.0" (406 mm) tall, 34.0" (864 mm) wide and 90.7" (2304 mm) long. The installed length of a joined chamber shall be 85.4" (2169 mm).
- 2.3 The chamber shall have a continuously curved section profile.
- 2.4 The chamber shall be open-bottomed.
- 2.5 The chamber shall incorporate an overlapping corrugation joint system to allow chamber rows of almost any length to be created. The overlapping corrugation joint system shall be effective while allowing a chamber to be trimmed to shorten its overall length.
- 2.6 The nominal storage volume of a joined StormTech SC-740 chamber shall be 74.9 ft³ (2.1 m³) per chamber when installed per StormTech's typical details (includes the volume of crushed angular stone with an assumed 40% porosity). This equates to 2.2 ft³ (0.67 m³) of storage/square foot of bed. The nominal storage volume of an installed StormTech SC-310 chamber shall be 31.0 ft³ (0.88 m³) per chamber when installed per StormTech's typical details (includes the volume of crushed angular stone with an assumed 40% porosity). This equates to 1.3 ft³ (0.40 m³/m²) of storage/square foot of bed.
- 2.7 The chamber shall have forty-eight orifices penetrating the sidewalls to allow for lateral conveyance of water.

- 2.8 The chamber shall have two orifices near its top to allow for equalization of air pressure between its interior and exterior.
- 2.9 The chamber shall have both of its ends open to allow for unimpeded hydraulic flows and visual inspections down a row's entire length.
- 2.10 The chamber shall have 14 corrugations.
- 2.11 The chamber shall have a circular, indented, flat surface on the top of the chamber for an optional 4" (100 mm) inspection port or clean-out.
- 2.12 The chamber shall be analyzed and designed using AASHTO methods for thermoplastic culverts contained in the LRFD Bridge Design Specifications, 2nd Edition, including Interim Specifications through 2001. Design live load shall be the AASHTO HS20 truck. Design shall consider earth and live loads as appropriate for the minimum to maximum specified depth of fill.
- 2.13 The chamber shall be manufactured in an ISO 9001:2000 certified facility.

3.0 END CAP PARAMETERS

- 3.1 The end cap shall be injection molded of Polypropylene resin to be inherently resistant to environmental stress cracking, and to maintain adequate stiffness through higher temperatures experienced during installation and service.
- 3.2 The end cap shall be designed to fit into any corrugation of a chamber, which allows: capping a chamber that has its length trimmed; segmenting rows into storage basins of various lengths.
- 3.3 The end cap shall have saw guides to allow easy cutting for various diameters of pipe that may be used to inlet the system.
- 3.4 The end cap shall have excess structural adequacies to allow cutting an orifice of any size at any invert elevation.
- 3.5 The primary face of an end cap shall be curved outward to resist horizontal loads generated near the edges of beds.
- 3.6 The end cap shall be manufactured in an ISO 9001:2000 certified facility.

16.0 Chamber Specifications for Contract Documents

STORMWATER CHAMBER SPECIFICATIONS:

1. Chambers shall be StormTech SC-740, SC-310 or approved equal.
2. Chambers shall conform to the requirements of ASTM F2418, "Standard Specification for Polypropylene (PP) Corrugated Wall Stormwater Collection Chambers."
3. Chamber rows shall provide continuous, unobstructed internal space with no internal support panels.
4. The structural design of the chambers, the structural backfill and the installation requirements shall ensure that the load factors specified in the AASHTO LRFD Bridge Design Specifications, Section 12.12 are met for: 1) long-duration dead loads and 2) short-duration live loads, based on the AASHTO Design Truck with consideration for impact and multiple vehicle presences.
5. Only chambers that are approved by the engineer will be allowed. The contractor shall submit (3 sets) of the following to the engineer for approval before delivering chambers to the project site:
 - A structural evaluation by a registered structural engineer that demonstrates that the load factors specified in the AASHTO LRFD Bridge Design Specifications, Section 12.12 are met. The 50-year creep modulus data specified in ASTM 2418 must be used as part of the AASHTO structural evaluation to verify long-term performance.
6. Chambers shall be produced at an ISO 9001 certified manufacturing facility.
7. All design specifications for chambers shall be in accordance with the manufacturer's latest design manual.
8. The installation of chambers shall be in accordance with the manufacturer's latest installation instructions.



20 Beaver Road, Suite 104 | Wethersfield | Connecticut | 06109
 860.529.8188 | 888.892.2694 | fax 866.328.8401 | fax 860-529-8040 | www.stormtech.com

StormTech products are covered by one or more of the following patents: U.S. Patents: 5,401,459; 5,511,903; 5,716,163; 5,588,778; 5,839,844; Canadian Patents: 2,158,418 Other U.S. and Foreign Patents Pending

Printed in U.S.A. © Copyright. All rights reserved. StormTech LLC, 2009



S070109